



Table of Contents

Products

Registers

RGS-3	4
TRGSU	9
TRGSUI	9
XRGSU	10
XRGSUI	10
SRTRGSU	11
SRTRGSUI	11
SRXRGSU	12
SRXRGSUI	12

Curved Registers

CREG	13
------	-------	----

Drum louvers

DRLAA	15
-------	-------	----

Ventiduct

VSR	18
-----	-------	----

Rectangular taps

RDTP	22
RDBTP	23



Registers for spiral ducts

RGS-3

4

General

Supply or exhaust registers shall be Linx Industries' RGS-3 for direct mounting on spiral ducts of sizes shown on the plans or outlet schedule.

The register is to be mounted without the use of a rectangular register tap. The top and bottom flanges are to meet flush with the spiral duct wall regardless of duct diameter. End caps shall be provided that conform to the varying duct diameter.

Materials

The register shall be manufactured of 22 gauge galvanized steel without further surface treatment. Welds or other surface discolorations on the register are unacceptable.

Construction

The register shall have double deflection adjustable blades with the front blades parallel to the short dimension of the register. Blades shall be placed on 3/4" centers and shall have steel friction pivots on both ends to allow for individual blade adjustment without loosening or rattling. Screw holes shall be countersunk for a flush, neat appearance.



Damper

The volume damper shall be of the single blade type manufactured from 22 gauge electro-galvanized steel. Volume damper shall be operable from the face of the register via a volume control rod. Notched rod shall be fixed in place by a tension lock located at the front of the register.

Performance

Performance of register shall be as per manufacturer's cataloged data. Manufacturers whose registers utilize a rectangular register tap to adapt to use with spiral duct shall submit correction factors for their cataloged data.



Registers for spiral ducts

RGS-3

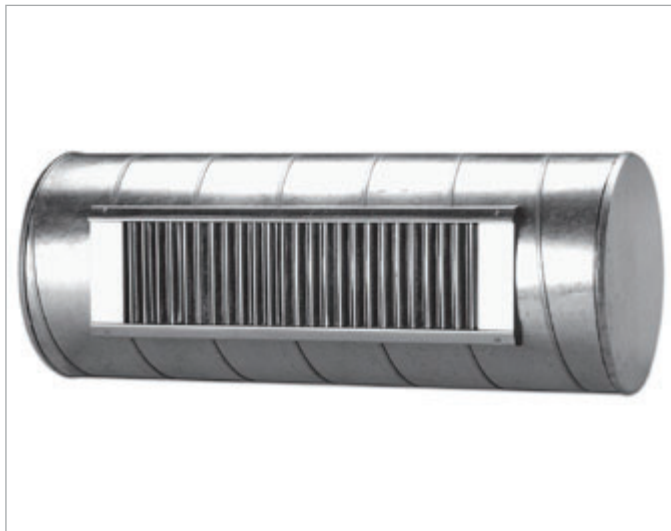

Dimensions

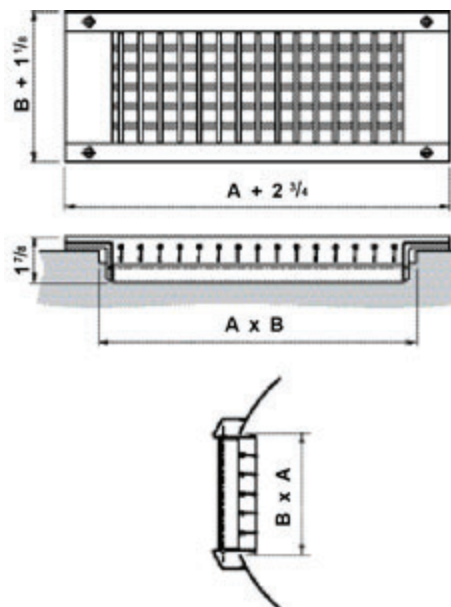

Description

The RGS-3 is a supply/return register with adjustable double deflection blades and a volume damper designed specifically for direct mounting on a spiral duct. The use of rectangular register taps are not required.

The register is designed in such a way that the flanges always meet flush to the duct regardless of the duct diameter in accordance with the minimum diameter on the chart. The RGS-3 comes equipped with end caps and gasketing material around the neck of the register. This prevents air leakage. The RGS-3 is manufactured from galvanized sheet steel and is assembled without the use of welding. This allows the register to be used without further surface treatment and gives it the same finish as the duct.

Materials and finish

Register: galvanized sheet steel

Damper: electro-galvanized sheet steel

Maintenance

The grille should be removed to gain access to the duct.

Order example RGS-3 13 3

Product	_____	_____	_____
Length (A)	_____	_____	_____
Width (B)	_____	_____	_____

Register nom. size (in)	Min. duct diameter (in)	Free area (ft ²)	Duct opening A x B (in)	Weight (lbs)
13 x3	6	0.18	12 ³ / ₄ x 3	2.4
17 x3	6	0.25	16 ³ / ₄ x 3	3.1
21 x3	6	0.30	20 ⁵ / ₈ x 3	3.7
25 x3	6	0.36	24 ⁵ / ₈ x 3	4.2
33 x3	6	0.48	32 ¹ / ₂ x 3	5.3
41 x3	8	0.60	40 ³ / ₈ x 3	6.4
49 x3	8	0.73	48 ¹ / ₄ x 3	7.1
13 x6	12	0.36	12 ³ / ₄ x 6	3.1
17 x6	12	0.48	16 ³ / ₄ x 6	4.2
21 x6	12	0.60	20 ⁵ / ₈ x 6	5.1
25 x6	12	0.73	24 ⁵ / ₈ x 6	5.7
33 x6	12	1.00	32 ¹ / ₂ x 6	7.7
41 x6	12	1.20	40 ³ / ₈ x 6	8.6
49 x6	12	1.46	48 ¹ / ₄ x 6	9.7
13 x9	20	0.60	12 ³ / ₄ x 8 ⁷ / ₈	4.8
17 x9	20	0.80	16 ³ / ₄ x 8 ⁷ / ₈	6.6
21 x9	20	1.00	20 ⁵ / ₈ x 8 ⁷ / ₈	7.5
25 x9	20	1.20	24 ⁵ / ₈ x 8 ⁷ / ₈	8.2
33 x9	20	1.60	32 ¹ / ₂ x 8 ⁷ / ₈	11.2
41 x9	20	2.00	40 ³ / ₈ x 8 ⁷ / ₈	12.8
49 x9	20	2.41	48 ¹ / ₄ x 8 ⁷ / ₈	13.9

Registers for spiral ducts

RGS-3

Mounting

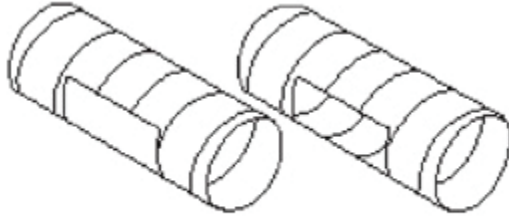

Remove the protective backing from template. Position the template on the duct and press firmly. Cut along the edges of the template, following the edges as closely as possible and remove the "cut-out".

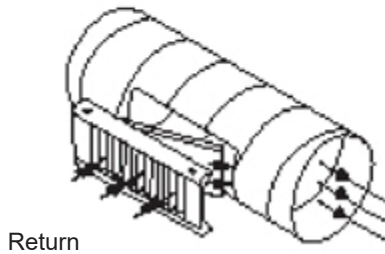
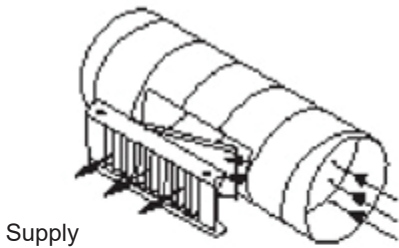

Insert the air extractor control rod through the tension lock on the face of the register. Position the RGS-3 register in the opening, making certain that the gasket material remains in place. Check that register has been installed correctly in relation to the direction of air flow.

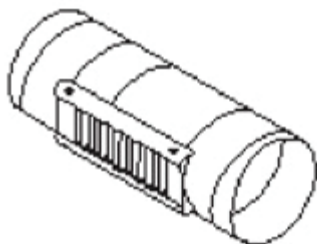

Secure the RGS-3 with screws (provided). Adjust vanes as necessary.

Balancing

- ① Air control extractor rod
- ② Probe

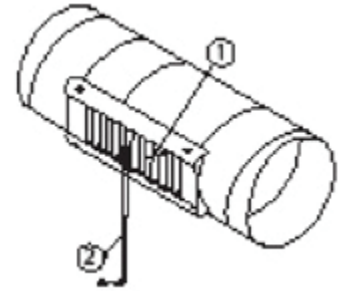

Mean velocity, V_o
 Measure velocity (V_n) in n number of points. First and last measurements is taken 6" from end of register.
 Measurements are spread equally between first and last measurement.

Flowrate [cfm] = $F \times V_o$
 V_o Mean velocity [fpm]
 F Flow factor

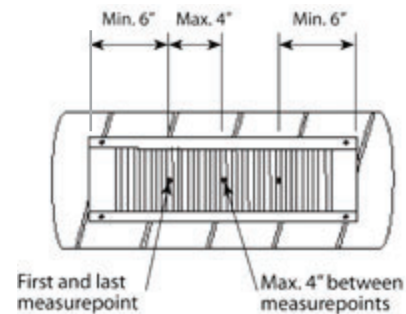

n = number of measurementpoints

$$V_o = \frac{\sum_{n=1}^n V_n}{n}$$

Dim. A	n
13"	2
17"	3
21"	3
25"	4
33"	5
41"	7
49"	7

Dim. A (in)	Dim. B					
	3"		6"		9"	
	Sup.	Ret.	Sup.	Ret.	Sup.	Ret.
13	0.18	0.135	0.36	0.27	0.60	0.45
17	0.25	0.19	0.48	0.36	0.80	0.60
21	0.30	0.23	0.60	0.45	1.00	0.75
25	0.36	0.27	0.73	0.55	1.20	0.90
33	0.48	0.36	1.00	0.75	1.60	1.20
41	0.60	0.48	1.20	0.90	2.00	1.50
49	0.73	0.55	1.46	1.10	2.41	1.18

Registers for spiral ducts

RGS-3

SELECTION CHART SUPPLY AND RETURN

Core velocity (fpm)			300	400	500	600	700	800	1000	1200
Velocity Pressure			0.006	0.010	0.016	0.023	0.031	0.040	0.063	0.090
Total Pressure		0°	0.011	0.019	0.028	0.039	0.052	0.067	0.101	0.141
		22.5°	0.012	0.021	0.032	0.044	0.059	0.075	0.114	0.159
Size		45°	0.019	0.033	0.049	0.069	0.092	0.117	0.177	0.248
A _c 0.18 (ft ²) 13 x 3	cfm		54	72	90	108	126	144	180	216
	NC	0°	-	-	-	14	20	25	33	40
	Throw ft	0°	3 4 7	6 7 12	8 9 18	10 12 23	12 14 27	14 17 32	17 21 40	19 25 47
		22.5°	3 2 5	5 5 10	6 7 14	8 10 18	10 11 22	11 13 25	13 17 32	15 20 37
		45°	2 2 3	3 3 6	4 5 9	5 6 11	6 7 14	7 8 16	8 10 20	9 12 23
A _c 0.24 (ft ²) 17 x 3	cfm		72	96	120	144	168	192	240	288
	NC	0°	-	-	12	18	24	29	37	44
	Throw ft	0°	3 5 9	6 8 15	8 11 20	10 13 25	12 16 30	14 18 34	17 22 42	19 26 49
		22.5°	3 4 7	5 6 12	7 8 16	8 11 20	10 13 24	11 14 27	14 18 34	15 21 39
		45°	2 2 5	3 4 7	4 5 10	5 7 13	6 8 15	7 9 17	8 11 21	10 13 25
A _c 0.30 (ft ²) 21 x 3	cfm		90	120	150	180	210	240	300	360
	NC	0°	-	-	14	21	26	31	39	46
	Throw ft	0°	3 6 11	6 9 17	8 12 22	11 14 27	12 17 32	14 19 36	17 23 44	19 27 51
		22.5°	3 5 9	5 7 13	7 9 17	8 11 21	10 13 25	11 15 29	14 18 35	15 21 41
		45°	2 3 6	3 4 8	4 6 11	5 7 13	6 8 16	7 9 18	9 12 22	10 13 25
A _c 0.36 (ft ²) 25 x 3, 13 x 6	cfm		108	144	180	216	252	288	360	432
	NC	0°	-	-	14	21	26	31	39	46
	Throw ft	0°	4 7 13	6 10 19	9 13 24	11 15 29	13 18 33	14 20 38	17 24 46	19 28 53
		22.5°	3 5 10	5 8 15	7 10 19	9 12 23	10 14 27	12 16 30	14 19 37	16 22 42
		45°	2 3 6	3 5 9	4 6 12	5 8 14	6 9 17	7 10 19	9 12 23	10 14 26
A _c 0.48 (ft ²) 33 x 3, 17 x 6	cfm		144	192	240	288	336	384	480	576
	NC	0°	-	12	20	27	32	37	45	52
	Throw ft	0°	4 9 16	7 12 22	9 14 27	11 17 32	13 19 37	15 22 41	18 26 49	20 30 56
		22.5°	3 7 13	5 9 17	7 11 22	9 14 26	10 15 29	12 17 33	14 21 39	16 24 45
		45°	2 4 8	3 6 11	4 7 14	6 8 16	7 10 18	7 11 21	9 13 25	10 15 28
A _c 0.60 (ft ²) 41 x 3, 21 x 6, 13 x 9	cfm		180	240	300	360	420	480	600	720
	NC	0°	-	15	23	29	35	40	48	54
	Throw ft	0°	4 10 19	7 13 25	9 16 30	12 18 35	13 21 40	15 23 44	18 27 52	20 31 59
		22.5°	4 8 15	6 10 20	8 13 24	9 15 28	11 17 32	12 19 35	14 22 42	16 25 47
		45°	2 5 10	4 6 12	5 8 15	6 9 17	7 10 20	8 12 22	9 14 26	10 16 29
A _c 0.73 (ft ²) 49 x 3, 25 x 6	cfm		219	292	365	438	511	584	730	876
	NC	0°	-	15	23	29	35	40	48	54
	Throw ft	0°	4 10 19	7 13 25	9 16 30	12 18 35	13 21 40	15 23 44	18 27 52	20 31 59
		22.5°	4 8 15	6 10 20	8 13 24	9 15 28	11 17 32	12 19 35	14 22 42	16 25 47
		45°	2 5 10	4 6 12	5 8 15	6 9 17	7 10 20	8 12 22	9 14 26	10 16 29
A _c 0.80 (ft ²) 17 x 9	cfm		240	320	400	480	560	640	800	960
	NC	0°	-	18	26	33	38	43	51	58
	Throw ft	0°	5 12 22	8 15 28	10 17 3	12 20 38	14 23 43	16 25 47	19 29 55	21 33 62
		22.5°	4 9 18	6 12 22	8 14 27	10 16 31	11 18 34	13 20 38	15 23 44	17 26 50
		45°	3 6 11	4 7 14	5 9 17	6 10 19	7 11 21	8 12 24	9 15 8	10 16 31

Registers for spiral ducts

RGS-3

SELECTION CHART SUPPLY AND RETURN

8

Core velocity (fpm)			300	400	500	600	700	800	1000	1200
Velocity Pressure			0.006	0.010	0.016	0.023	0.031	0.040	0.063	0.090
Total Pressure		0°	0.011	0.019	0.028	0.039	0.052	0.067	0.101	0.141
		22.5°	0.012	0.021	0.032	0.044	0.059	0.075	0.114	0.159
Size		45°	0.019	0.033	0.049	0.069	0.092	0.117	0.177	0.248
A _c 1.00 (ft ²) 33 x 6, 21 x 9	cfm		300	400	500	600	700	800	1000	1200
	NC	0°	10	21	29	35	41	46	54	61
	Throw ft	0°	6 13 24	8 16 30	11 18 35	13 21 40	15 23 44	16 26 49	19 30 57	21 34 64
		22.5°	5 10 19	7 12 24	9 15 28	10 17 32	12 19 36	13 21 39	15 24 45	17 27 51
		45°	3 6 12	4 8 15	5 9 17	6 10 20	7 12 22	8 13 24	10 15 28	11 17 32
A _c 1.20 (ft ²) 41 x 6, 25 x 9	cfm		360	480	600	720	840	960	1200	1440
	NC	0°	13	23	31	38	43	48	56	63
	Throw ft	0°	6 13 24	9 16 30	11 18 35	13 21 40	15 23 44	17 26 49	20 30 57	22 34 64
		22.5°	5 10 19	7 12 24	9 15 28	11 17 32	12 19 36	14 21 39	12 24 45	18 27 51
		45°	3 6 12	4 8 15	6 9 17	7 10 20	8 12 22	9 13 24	10 15 28	11 17 32
A _c 1.46 (ft ²) 49 x 6	cfm		438	584	730	876	1022	1168	1460	1752
	NC	0°	15	25	33	40	46	50	59	65
	Throw ft	0°	7 11 21	10 14 27	12 17 32	14 20 37	16 22 42	18 24 46	21 29 54	23 32 61
		22.5°	6 9 17	8 11 22	10 14 26	11 16 30	13 18 34	14 20 37	17 23 43	18 26 49
		45°	4 6 11	5 7 14	6 8 16	7 10 19	8 11 21	9 12 23	10 14 27	11 16 31
A _c 1.60 (ft ²) 33 x 9	cfm		480	640	800	960	1120	1280	1600	1920
	NC	0°	16	26	35	41	47	52	60	66
	Throw ft	0°	8 10 19	10 13 25	13 16 30	15 18 35	17 21 39	18 23 44	21 27 52	23 31 59
		22.5°	6 8 15	8 10 20	10 13 24	12 15 28	13 17 32	15 18 35	17 22 41	19 25 47
		45°	4 5 9	5 6 12	6 8 15	7 9 17	8 10 2	9 12 22	11 14 26	12 15 29
A _c 2.00 (ft ²) 41 x 9	cfm		600	800	1000	1200	1400	1600	2000	2400
	NC	0°	19	29	37	44	49	54	62	69
	Throw ft	0°	9 12 22	12 15 28	14 18 34	16 21 40	18 23 44	20 26 49	23 29 56	25 32 61
		22.5°	7 9 18	9 12 23	11 14 27	13 17 32	14 19 35	16 20 39	18 23 45	20 26 49
		45°	4 6 11	6 7 14	7 9 17	8 10 20	9 12 22	10 13 24	11 15 28	12 16 30
A _c 2.41 (ft ²) 49 x 9	cfm		723	964	1205	1446	1687	1928	2410	2892
	NC	0°	21	31	40	46	52	57	65	71
	Throw ft	0°	10 13 5	13 17 32	15 20 38	17 23 43	19 25 48	21 27 52	24 31 59	26 34 64
		22.5°	8 11 20	10 13 25	12 16 30	14 18 34	15 20 38	17 22 41	19 25 47	21 27 51
		45°	5 7 13	6 8 16	8 10 19	9 11 21	10 13 24	10 14 26	12 16 29	13 17 32

Fitting bodies

TRGSU

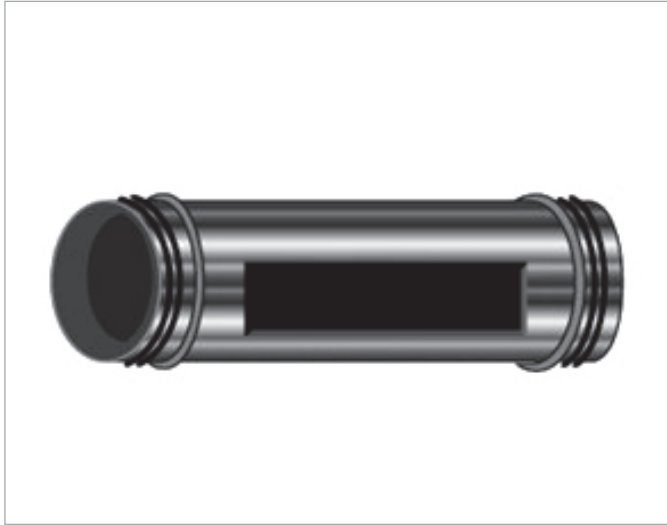

Description

Single wall smooth fitting body
 Length of body = $A+10$
 Register sold separately

Dimensions

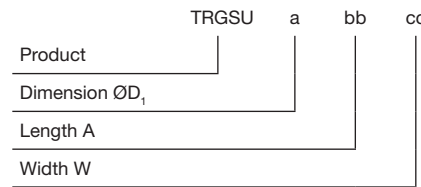
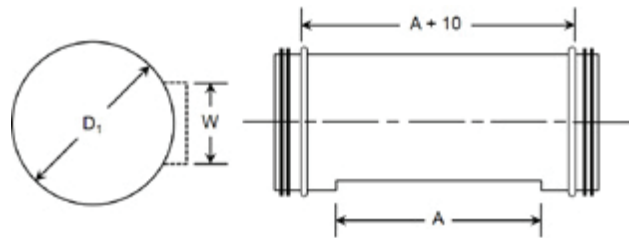

TRGSUI



Description

Double Wall smooth fitting body with mounted register (RGS)
 Length of body = $A+10$

Dimensions

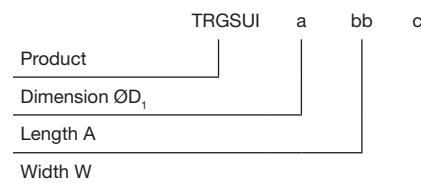
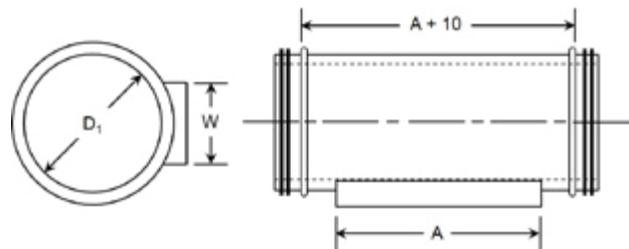

Crossing fitting bodies

XRGSU

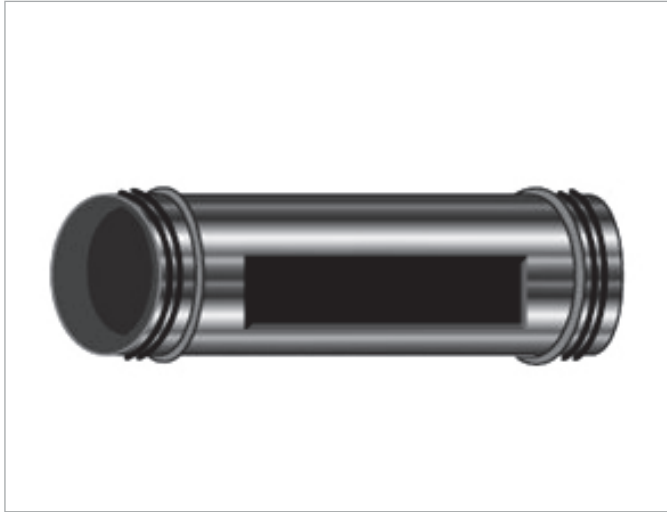

Description

Single wall smooth fitting body cross
 Length of body = $A+10$
 A = largest (A_2 or A_1)
 Register sold separately

Dimensions

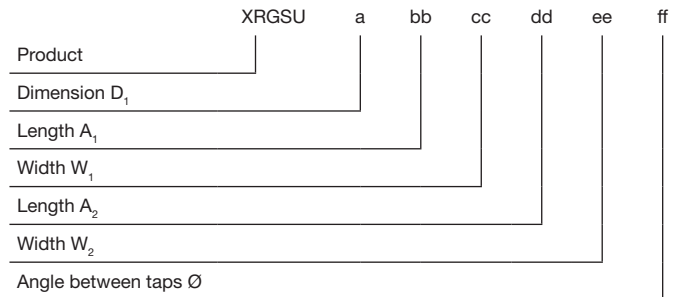
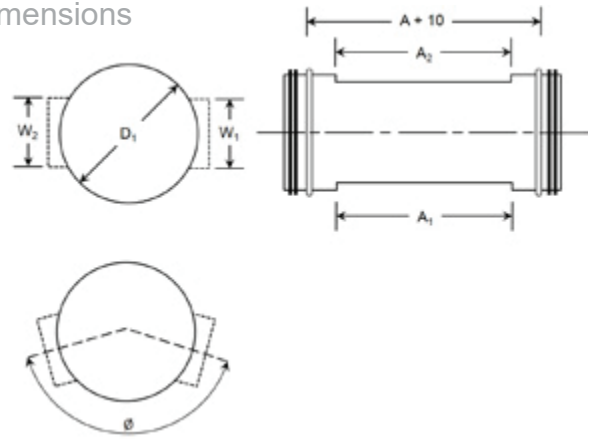

XRGSUI

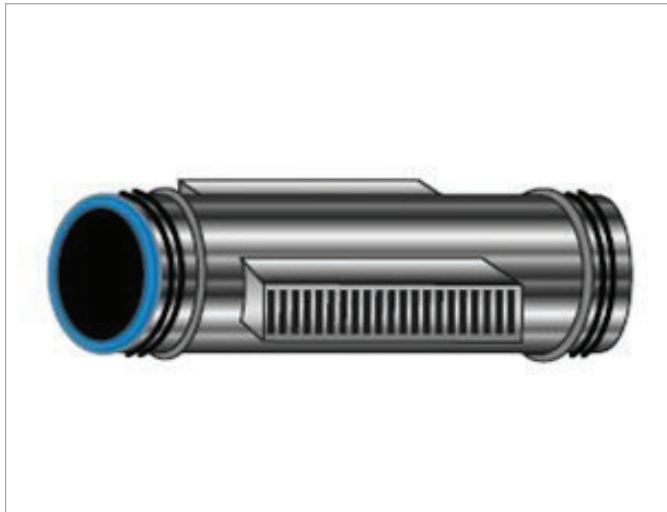

Description

Double wall smooth fitting body cross with mounted registers (RGS)
 Length of body = $A+10$
 A = largest (A_2 or A_1)

Dimensions

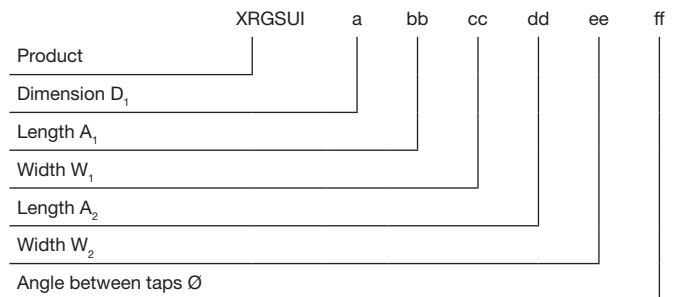
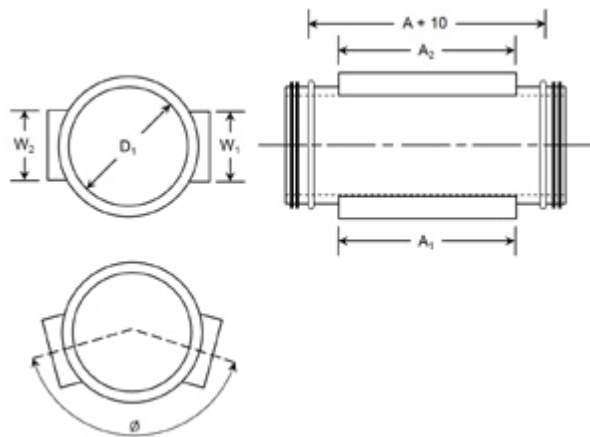

Spiral bodies

SRTRGSU

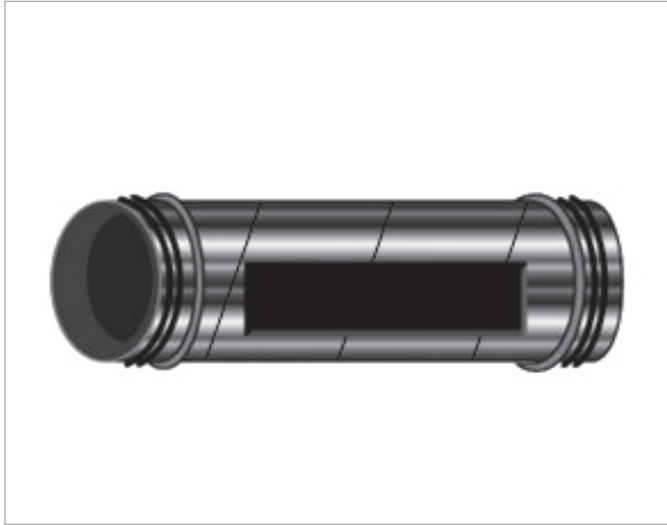

Description

Single wall spiral fitting body
 Length of body = $A+10$
 Register sold separately

Dimensions

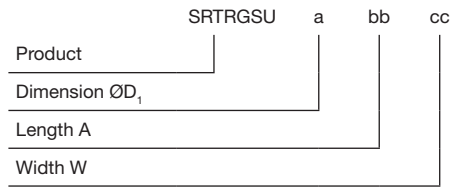
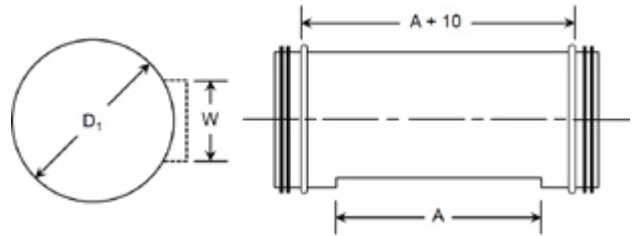

SRTRGSUI

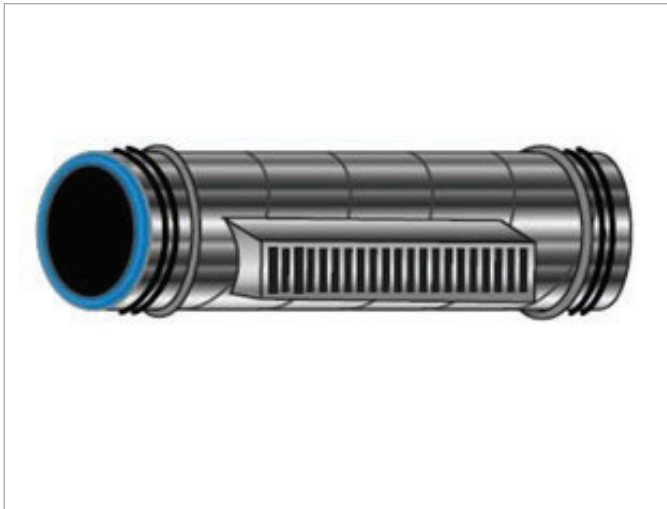

Description

Double wall spiral fitting body with mounted register (RGS)
 Length of body = $A+10$

Dimensions

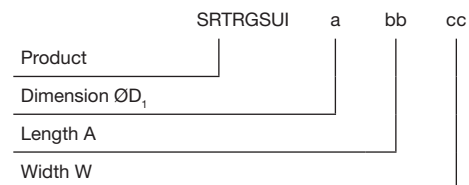
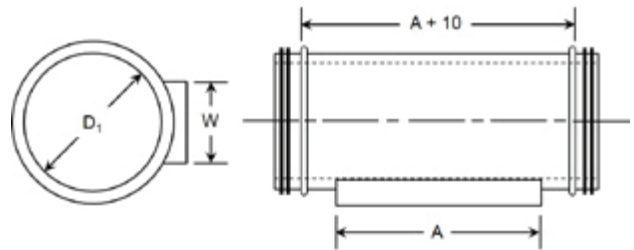

Curved register

CREG

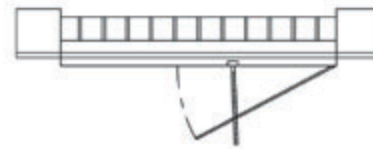
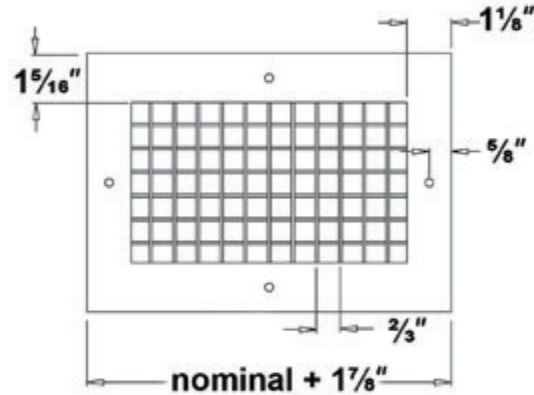
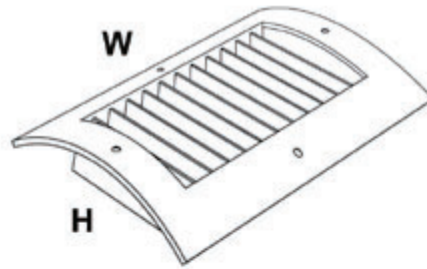

Description

The CREG is a supply/return register with a contoured face that mounts directly on spiral ductwork. It has adjustable double deflection blades that allow for 4-way airflow and half length screwdriver operated volume adjusting scoop.

Duct diameter must be 4" larger than height (H) of diffuser. Registers are manufactured to fit duct diameters 8" - 48".

Materials and finish

Galvanized sheet steel (standard).
Custom finishes are available. Call for details.

Register nom. size W x H (in)	Min. duct diameter (in)	Free area (ft ²)	Duct opening W X H (in)	Weight (lbs)
12 x 4	8	0.231	12 x 4	1.8
14 x 4	8	0.271	14 x 4	2.1
12 x 6	10	0.362	12 x 6	2.5
14 x 6	10	0.425	14 x 6	2.9
16 x 6	10	0.488	16 x 6	3.3

Order example

	CREG	12	4	16	Galv	None
Product	_____	_____	_____	_____	_____	_____
Width (W)	_____	_____	_____	_____	_____	_____
Height (H)	_____	_____	_____	_____	_____	_____
Diameter of Duct	_____	_____	_____	_____	_____	_____
Material	_____	_____	_____	_____	_____	_____
Finish	_____	_____	_____	_____	_____	_____



Core velocity (fpm)			300	400	500	600	700	800	1000	1200
Velocity Pressure			0.004	0.008	0.013	0.018	0.025	0.033	0.051	0.074
Size										
A _c 0.231 (ft ²) 12 x 4	cfm		69	92	116	139	162	185	231	277
	NC	0°	< 20	< 20	< 20	20	25	30	35	40
	Throw ft	0°	5 6 6.5	6 7 9	8 9 11	9 10 14	11 12 16	12 14 18	14 16 24	16 18 28
A _c 0.271 (ft ²) 14 x 4	cfm		81	108	136	163	190	217	271	325
	NC	0°	< 20	< 20	< 20	20	25	30	35	40
	Throw ft	0°	5 7 8	7 8 10	10 11 13	11 12 16	13 15 20	14 16 22	16 19 29	19 22 34
A _c 0.362 (ft ²) 12 x 6	cfm		109	145	181	217	254	290	362	435
	NC	0°	< 20	< 20	< 20	20	25	30	35	40
	Throw ft	0°	6 7 8	8 9 11	10 12 14	12 13 18	14 16 21	16 18 24	18 21 32	22 26 38
A _c 0.425 (ft ²) 14 x 6	cfm		128	170	213	255	298	340	425	510
	NC	0°	< 20	< 20	< 20	20	25	30	35	40
	Throw ft	0°	6 8 9	9 10 12	11 12 15	12 14 19	14 16 22	17 19 25	19 22 33	22 26 39
A _c 0.488 (ft ²) 16 x 6	cfm		146	195	244	293	342	391	488	586
	NC	0°	< 20	< 20	< 20	20	25	30	35	40
	Throw ft	0°	7 8 10	9 10 12	11 13 16	13 15 20	15 17 23	17 20 26	19 22 34	23 27 40

Performance notes:

- 1.) Performance data calculated with blades set at 0°.
- 2.) Engineering based off nominal face dimension.
- 3.) Throw values are measured in feet for terminal velocities of 150/100/50 FPM.
- 4.) Throw data is based on supply air and room air both at isothermal conditions.
- 5.) Effective core areas listed in chart are defined as the measurement of space between the blades actually utilized by the air.
- 6.) Data obtained from tests conducted in accordance with ANSI/ASHRAE standard 70-2006.

Drum louvers

DRLAA

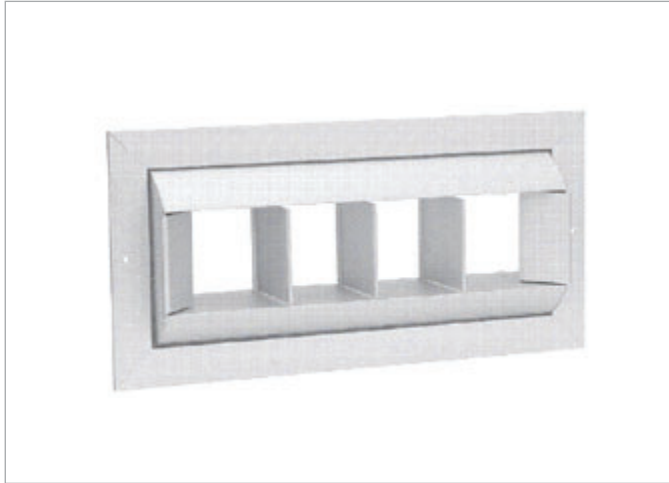

Dimensions

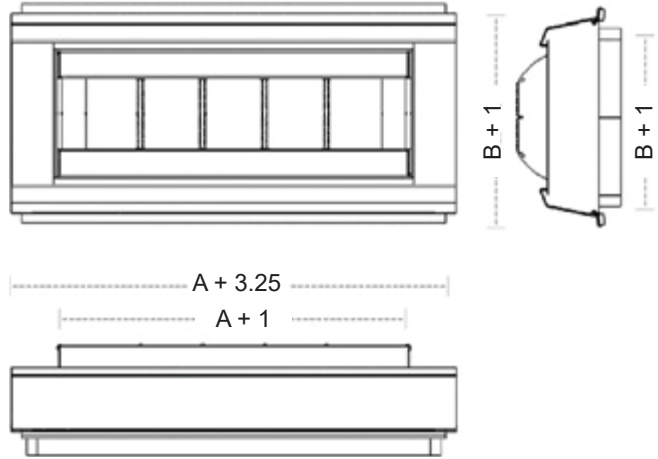

Description

DRLAA series supply drum grilles and registers are recommended for theaters, arenas, convention halls, factories and shopping centers; anywhere requiring long or short throws.

Air flow patterns are adjustable in both the horizontal and vertical planes for maximum versatility.

The unique extruded aluminum universal mounting frame results in low installation costs and will adapt to a variety of duct sizes without requiring any expensive duct taps.

The extractor-damper that is available will also eliminate the need for secondary extraction devices needing to be mounted remote to the unit. DRLAA grilles and registers efficiently distribute anywhere from 200 through 10,000 CFM and are available in 6 x 12 through 10 x 72 sizes.

DRLAA drum grilles are built with a single bank of adjustment vanes that also provides control for the direction and length of air streams. DRLAA drum grilles and registers can be installed in either horizontal or vertical orientations to meet architectural and engineering design conditions for reliable performance.

A Width (in)	B Height (in)	
	6	10
12	X	
18	X	
24	X	X
30	X	X
36	X	X
42		X
48	X	X
54		X
60	X	X
66		X
72		X

Height (in)	6	10
Duct Diameter (min/max)	10 / 65	20 / 97

Order example

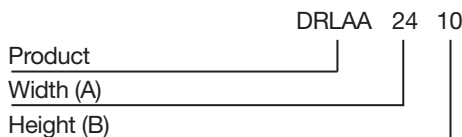

Engineering data

Throw Chart

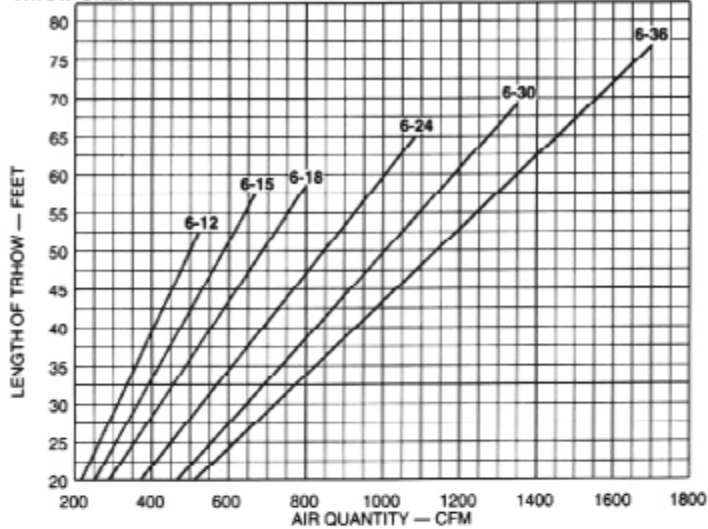

Pressure Requirements

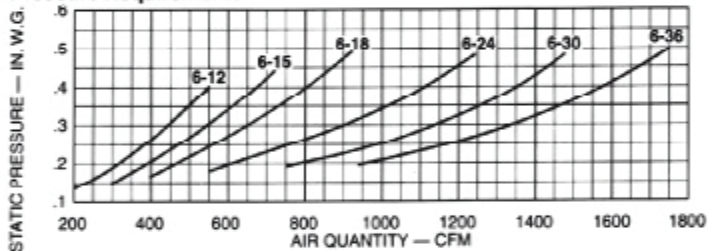

Sound Levels — NC

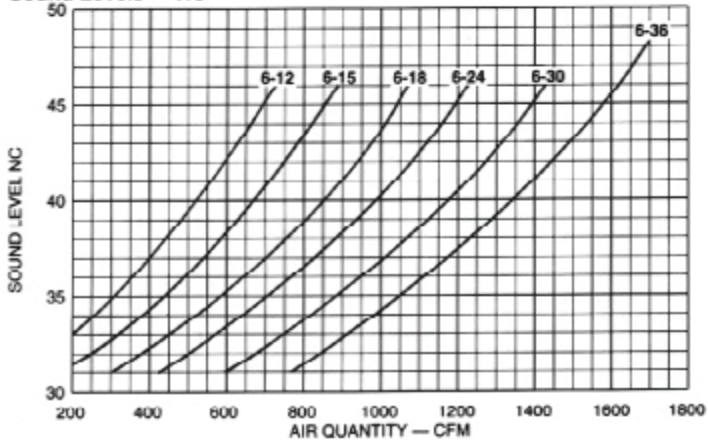

A_k Outlet Area In Square Feet

Unit Size	A _k
06-12	0.181
06-15	0.226
06-18	0.277
06-24	0.381
06-30	0.484
06-36	0.536
10-24	0.710
10-30	1.024
10-36	1.233
10-42	1.495
10-48	1.626
10-54	1.757
10-60	1.888
10-66	2.019
10-72	2.150

Products Notes (6):

1. Throws are based on terminal velocity of 50 fpm. Throws can be reduced up to 35% by adjustable vane settings.
2. Test data based on 70 °F air with rotating barrel and adjustable vanes set parallel to air flow for maximum projection.
3. NC based upon 8dB room absorption.

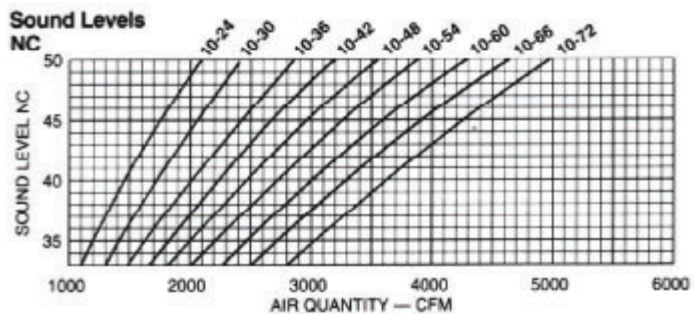
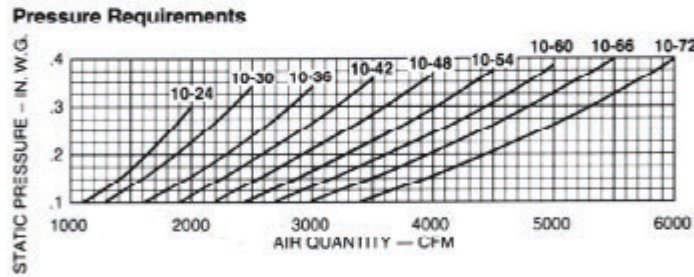
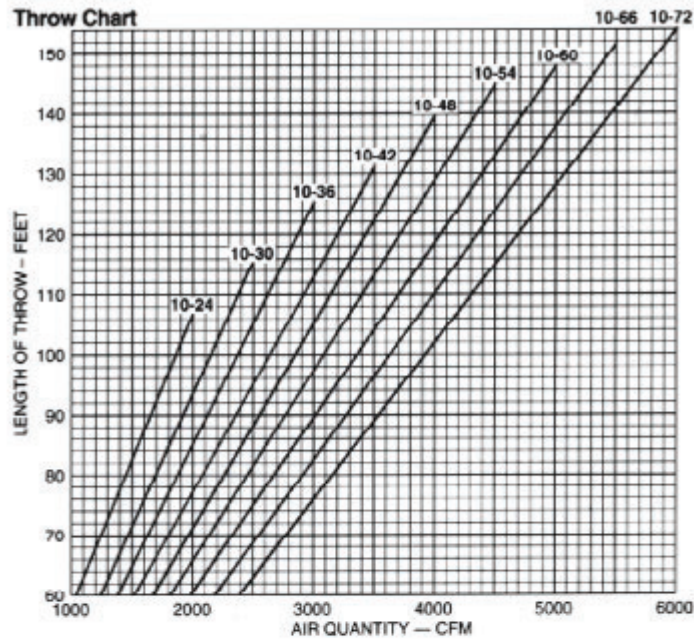

Products Notes (10):

1. Throws are based on terminal velocity of 50 fpm. Throws can be reduced up to 35% by adjustable vane settings.
2. Test data based on 70 °F air with rotating barrel and adjustable vanes set parallel to air flow for maximum projection.
3. NC based upon 8dB room absorption.

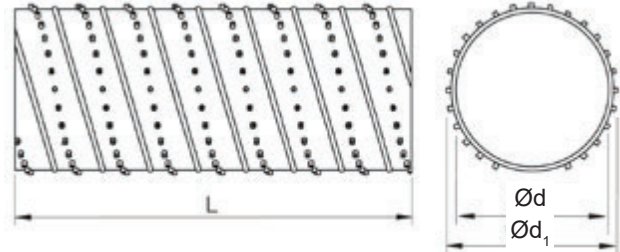

Description

Ventiduct is an air distribution system consisting of spiral ducts enhanced by a number of small nozzles carefully placed into the duct wall. VSR can be ordered with various nozzle patterns for specific demands.

- Large cooling effect
- Large dynamic range
- Large induction rate
- Short throw
- Discrete diffuser design
- Easy to install
- Supplied in five sizes ranging from 8", 10", 12", 16", 20" Ø
- Available in lengths between 12" to 60"
- Standard G90 construction
 - Optional: epoxy-coated

Dimensions

Ød	Ød ₁
inch	inch
8	8.4
10	10.4
12	12.4
16	16.4
20	20.4

Order example

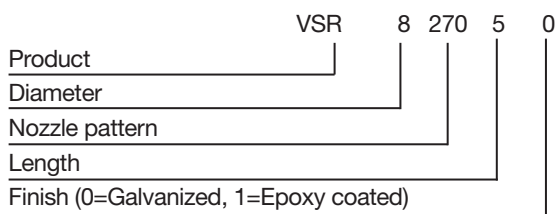

Nozzle Pattern

Code

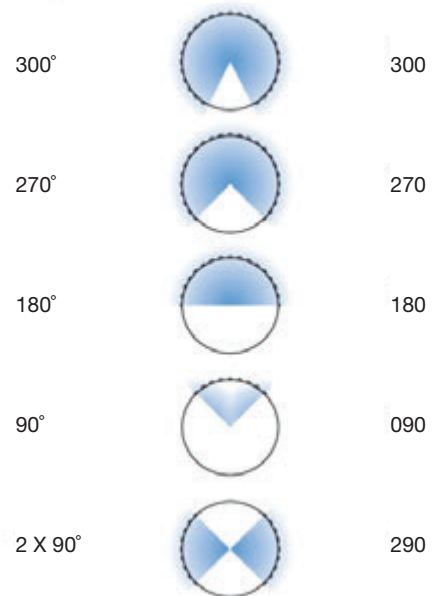

Dispersal patterns

With Ventiduct nozzle ducts, various flow conditions can be achieved in the room. The downward supply of air always creates the greatest air velocities in the occupied zone and is therefore used mostly in industrial ventilation. The choice between air being supplied horizontally or upwards depends on the required form of flow.

Upward supply air

When cooled air is supplied upwards, the cool air mixes with the warmer room air close to the duct nozzles. The supplied air typically covers a vertical area of 78" to 158" below the ducts. At greater distances between the ducts, the supplied air flows behind in a displacement flow further out in the room.

Depending on the required volume flow, a nozzle pattern of between 90° and 300° is used.

Downward supply air

When air is supplied downwards, the air velocities in the occupied zone are increased by the thermal forces (by cooling) and by the dynamic forces (Supplied air velocity). This can result in quite high air velocities in the occupied zone, which is not acceptable for traditional comfort ventilation. However, high air velocities can be recommended if a stable downward flow of air is required, and if increased, air velocities in the occupied zone are acceptable. This could, for example, be desirable for industrial applications. A nozzle pattern between 90° and 300° is used, depending on the volume flow required.

Horizontal supply air

When air is supplied horizontally, air jets are formed, creating a mixed flow in the room. Depending on the various parameters, maximum air velocities occur in the occupied zone due to the thermal load, air jet velocities or a combination of both. When low supply air velocities are being used (low volume flow or large ducts/nozzle patterns) the form of the flow approximates a form of low impulse supply air, as with upwards supply air. Horizontal supply air can be used in locations where there is a deliberate demand for a flow of air throughout the room in accordance with the mixing principle, and therefore where an upward supply is not being used.

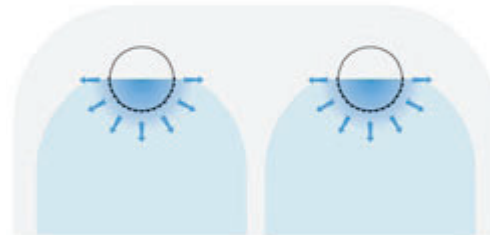
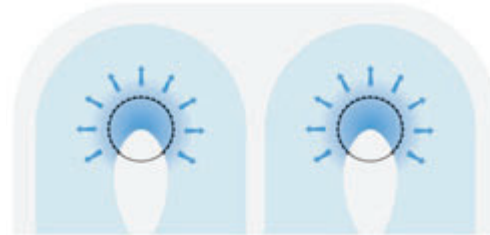

Recommended working areas for Ventiduct

The values stated are for guidance only and should be used with care, as incoming volume flow, cooling temperature, duct design and air pattern all have a great deal of influence on the resulting air velocity in the occupied zone.

For more detailed calculations, Linx Industries will be happy to perform a computer calculation.

Air pattern	Up	Down	Horizontal
Installation height [in] *	98-197	118-315	98-197
Min. distance from ceiling [in] **	8	4-8	4
Δt (t1 - tr) [K]	-1..-10	-1..-6	-1..-8

* Distance from floor to lower edge of duct

** Distance from upper edge of duct to ceiling must be maintained to avoid dirtying the ceiling

Technical data

Examples of duct design

Ventiduct nozzle ducts can be installed in various ways. In high-ceilinged rooms it is generally an advantage to install Ventiduct nozzle ducts as low down as possible (min. height above floor 96"). This provides the greatest efficiency.

Cactus model

This solution is used for long, narrow rooms.

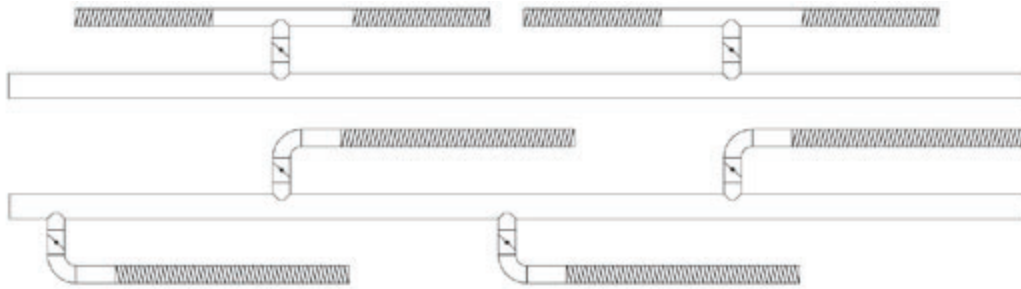

Exchange model

An ideal solution for long, narrow rooms. This model provides an even distribution of supplied air.

Fishbone model

Ventiduct nozzle ducts stretch out from both sides of the main duct. It is recommended that a volume damper be used for accurate regulation of the air volume.

Fork model

Here the Ventiduct nozzle ducts are positioned on one side of a main or branch duct. It is recommended that a volume damper be installed on the duct joins in order to ensure consistent air distribution in the duct system.

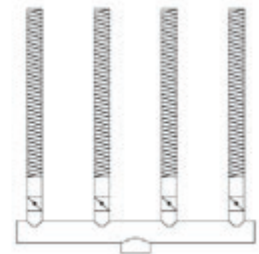
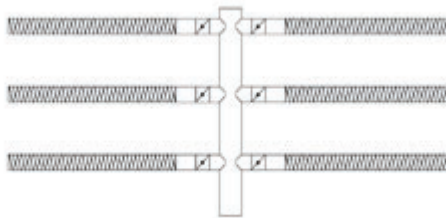
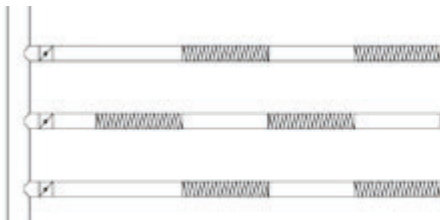

Line model

A simple solution that makes duct installation easier and minimizes the number of volume dampers. The distance between the connection ducts is equivalent to twice Ventiduct's maximum length plus the two blind pieces.

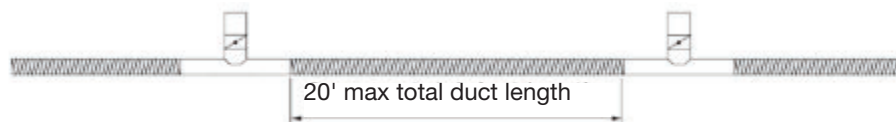

Technical data

Building-in distance

Ventiducts should not be positioned too close to dampers, elbows, tees or other elements that may create turbulence and hence noise.

Straight duct sections should be installed between the Ventiducts and potentially disruptive components, as shown in the illustration below. Suitable duct sections are available.

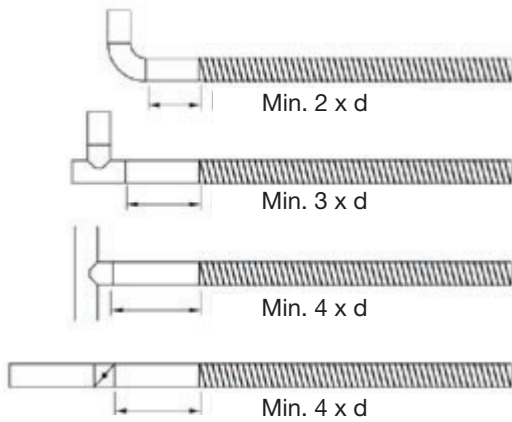

Mounting

Assembly

The Ventiducts are individually packed in cardboard boxes at the factory, to minimize the risk of transport damage. The packaging is numbered to ensure that the ducts are mounted in the correct order, so that the spiral seam is continuous.

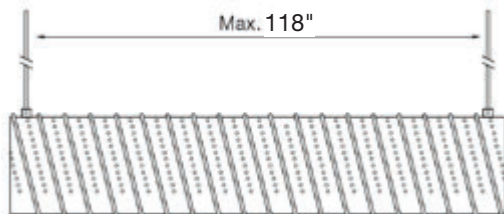
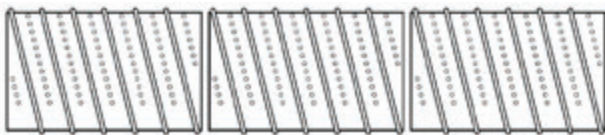

Maximum distance between suspension loops is 118"

Air velocity in the occupied zone

The air velocity in the occupied zone is a result of air jet velocities and thermal air movements in the room. An exact calculation of the resulting air velocity in the occupied zone can be performed using a computer program. (Contact the Linx Industries sales department for further information).

For upward supply, the maximum air velocity in the occupied zone are dependent on the temperature difference $t_i - t_r$. The best results are achieved by using maximum supply air per duct foot, according to the table on the left.

Depending on the thermal load (W/ft^2) and the duct length, the maximum air velocity in the occupied zone is indicated as a rough estimate in the diagram below.

Diagram only applies to upward dispersal pattern with maximum volume flow per duct foot:
(distance to ceiling $> 4 \times \varnothing d$).

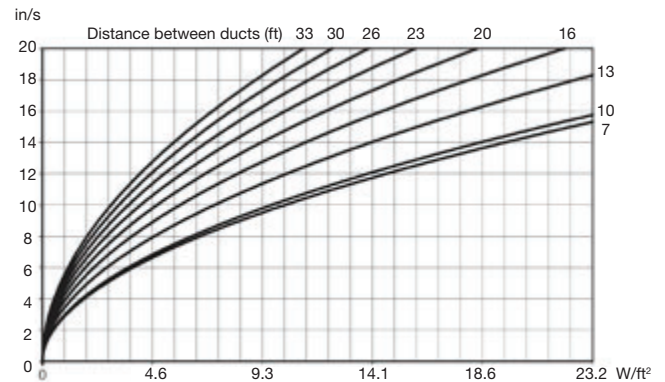

Please contact Linx Industries's sales department for further information.



Description

The RDTP is a heavy duty, high capacity rectangular tap off of round duct. RDTP's are designed specifically for direct mount applications on round duct, to accept mounting of register grilles.

The base of the RDTP is fabricated to the outside radius of the duct on which it is to be mounted. The grille mount side can be ordered with a flanged surface, either turned in or turned out, or a raw end can also be requested.

Standard Features:

- 1" flange turned in
- H = 6"
- W ≤ outside duct diameter
- Single wall

Options:

- Flange turned out or plain
- Various flange widths
- Various tap heights
- Double wall or lined

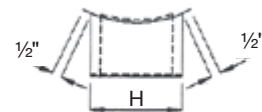
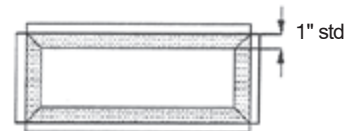
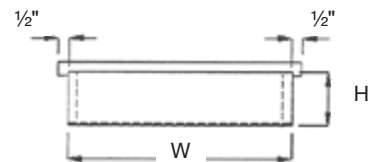
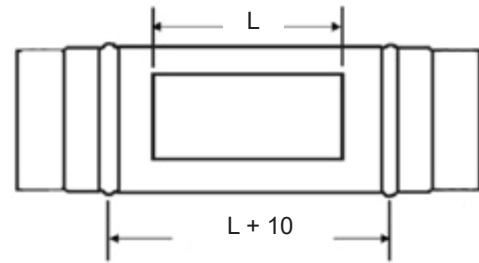

Order example

Product Code: RDTP D - L x W - H - F

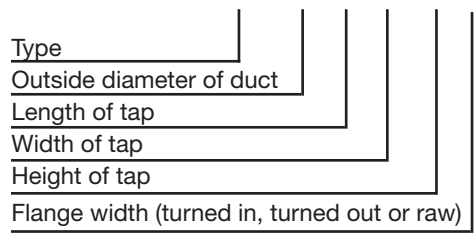

Rectangular taps

RDBTP

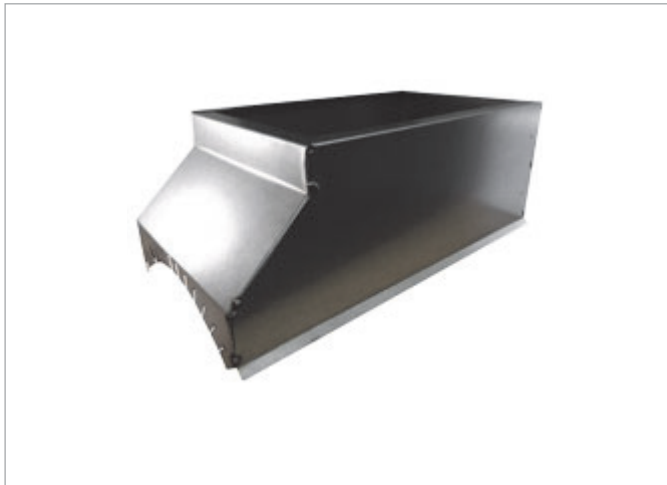

Description

The RDBTP is a heavy duty, high capacity rectangular boot tap off of round duct. RDBTP's are designed specifically for direct mount applications on round duct, to accept mounting of register grilles.

The base of the RDBTP is fabricated to the outside radius of the duct on which it is to be mounted. The grille mount side can be ordered with a flanged surface, either turned in or turned out, or a raw end can also be requested.

Standard Features:

- galvanized sheet steel
- "tack and seal" assembled
- Height is 6", where S = 2" and B = 4"
- Flange width is 1" turned in

NOTE: S = Amount of straight, B = Boot Height
 $S + B = H$ (Ex. $6 + 3 = 9$)

Options:

- Flange turned out or plain (raw)
- Various flange widths
- Various tap heights
- Double Wall or lined

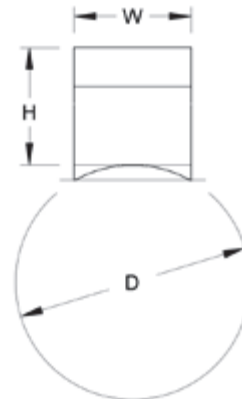
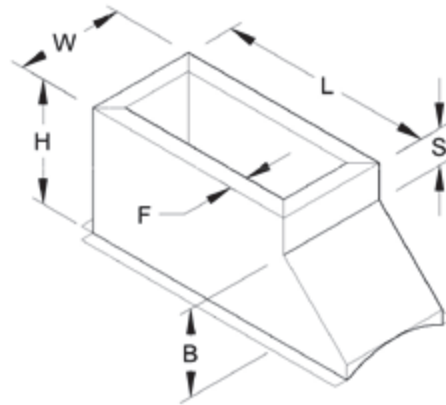

Order example

Product Code: RDBTP D - L x W - H - F

Type	
Outside diameter of duct	
Length of tap	
Width of tap	
Height of tap	
Flange width	



Linx Industries, Inc.
2600 Airline Boulevard
Portsmouth, Virginia 23701
Phone: 800.797.7476
Fax: 757.488.4502
www.li-hvac.com



REV04.2016

We reserve the right to make changes without prior notice. Therefore, all designs, specifications, and product features are subject to change without notice. The company and its products are protected by patents and registered trademarks. Linx Industries, Inc. Copyright 2016 All rights reserved.